

G-2 SHOCK ASSEMBLY

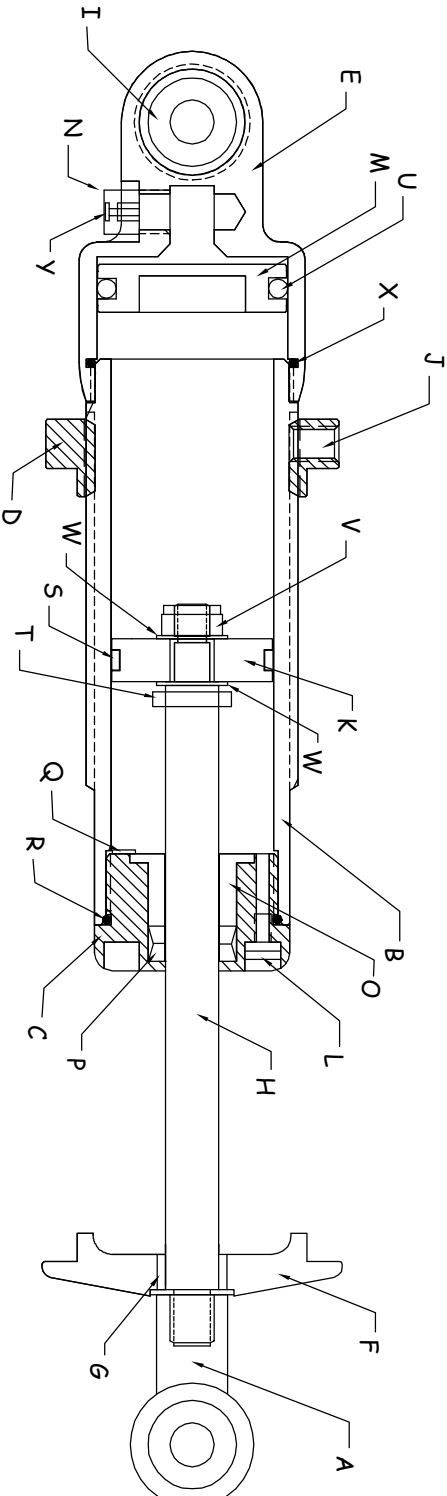

SHOCK REBUILDING

INDEX

A=	8551-110	Rod End
B=	8551-010	Shock Body
C=	8551-030	Shaft Guide (BARE)
D=	8551-060	Adjustment Nut
E=	8551-020	Separator Cap
F=	8551-040	Spring Cone
G=	8551-050	Cone Spacer
H=	8551-070	Shaft
I=	8551-120	Spherical Bearing
J=	8551-190	#6 Set Screw
(J)=	8551-200	#10 Set Screw (after 4/05)
K=	8551-080	Control Piston
L=	8551-170	Bleed Screw
M=	8551-090	Separator Piston
N=	8551-100	Gas Fill Port
O=	8551-150	Bronze Bushing
P=	8551-140	U-Cup (2)
Q=	8551-160	Bushing Retainer Screw
R=	8551-230	Shaft Guide O-Ring
S=	8551-220	Control Piston Band
T=	8551-270	Internal Bumper O-Ring
U=	8551-280	Separator Piston O-Ring
V=	8551-260	1/4-28 Nylock Nut
W=	8551-250	1/4" Washer (2)
X=	8551-240	Separator cap O-ring
Y=	8551-210	Valve Core

1. Clamp shock into vice using shock jaws (Part # 75570) with the rod end facing upward.
2. Remove the schrader valve from the gas port using the valve core removal tool (Part # 22460).
3. Remove the bleeder screw from the shaft guide.
4. Remove the shaft guide, rod and piston assembly from the shock body using the shock wrench (Part # 75575).
5. Remove the shock body from the vice and clamp the shaft assembly in the vice.
6. Remove the 1/4-28 nut from the shaft and pull off the piston, washers and shaft guide assembly.
7. Remove the bushing retainer screw, and using the end of the shaft (or something similar) push the bronze bushing out from the bottom side of the shaft guide.
8. Remove the old u-cup seals and clean out the shaft guide using cleaner such as brake cleaner or solvent.
9. Insert new u-cup seals facing the proper direction (see drawing above).
10. Clean and reinstall existing bronze bushing (this very rarely wears out) and bushing retainer screw.
11. Change the o-ring on the outside of the shaft guide and reassemble shaft guide, piston, washers and nut back onto the shaft.
12. Dispose of all remaining shock oil left in the shock body and clean the body internally to remove any contaminants. (If no oil was present in the gas fill port (N) upon disassembly you can skip to step 20 as it is not necessary to do steps 13-19.)
13. Grip the shock body in the vice with the separator cap assembly facing upwards using shock body jaws (Part # 75572).
14. Using the slot in the shock wrench, remove the separator cap assembly (this part is located on so it may be difficult to remove).
15. Screw the inflation adapter (part # 75580) into the gas port and blow out the separator piston using low pressure air.
16. Change the o-ring on the separator piston and reassemble separator piston into the separator cap making sure that is is pressed all the way down.
17. Clean all of the old loctite off of the threads of the shock body.
18. Put new loctite on the threads of the shock body and reinstall the separator cap assembly making sure not to get any loctite on the inner surfaces of the shock.
19. Allow the loctite to dry for a minimum of 15 minutes, then turn the shock back over in the vice and grip with the shock jaws.
20. Fill the shock with oil to the bottom of the internal threads.
21. Place the drip cup onto the shock (part # 75566).
22. With the shaft guide about half way up the shaft, slowly reinstall the shaft assembly moving it up and down slightly to remove all air bubbles.
23. Tighten the shaft guide assembly with the shock wrench, then slowly depress the shaft until the cone spacer hits the shaft guide.
24. Reinstall the bleed screw.
25. Reinstall the schrader valve into the gas port and screw in the inflation adapter.
26. Inflate the shock to 60 psi and let the shock set for about 15 minutes to check for any leaks (air or oil).
27. Let the air back out of the shock and re-inflate to desired pressure (factory setting 20psi).